

深圳市瑞隆源电子有限公司 SHenzhen Ruilongyuan Electronics Co.,Ltd			
产品名称 Product name	复合防护单元 Keep Off Varistor	产品型号 Product Type	KOV14D&20D@TA
文件编号 File serial number	SP-SPD-448	产品编码 Product code	10.20.42.xxxx-0000
类别 Classification	<input type="checkbox"/> 参考阶段 Reference <input type="checkbox"/> 样品阶段 Sample <input checked="" type="checkbox"/> 正式承认 Qualified <input type="checkbox"/> 工程变更 Changed		

拟制: Prepared by	Zoujinhua	日期: Date	2026.06.23
审核: Reviewed by	Shennengwu	日期: Date	2026.06.23
批准: Approved by	Robert	日期: Date	2026.06.23

修订版本 Revision Version	描述 Description	页码 Page	日期 Date
A0	正式承认 Qualified	/	2026.04.22
A1	Delete "T2/In/3kA" of Performance Parameters	3, 4	2026.06.23

产品简述 Product Description

KOV 系列产品采用特有的温度保护技术，将 MOV 元件从失效崩溃的瞬间从电路中解放出来，从而防止了次生灾害（高温、燃烧）的发生。这些系列产品的设计完全遵循了 UL 1449、IEC 61643-331 以及 IEC61051 的要求，并获得了相关认证。在应对暂态过电压和过电流的测试项目，完全参照满足了 IEC 61643-11 和 UL 1449 Type 4CA 的要求。The KOV series products adopt a unique temperature protection technology, which frees MOV (Metal Oxide Varistor) components from the circuit at the moment of their failure and collapse, thereby preventing secondary disasters (high temperature, combustion). The design of these series products fully complies with the requirements of UL 1449, IEC 61643-331, and IEC 61051, and has obtained relevant certifications. For the test items related to transient overvoltage and overcurrent, they completely refer to and meet the requirements of IEC 61643-11 and UL 1449 Type 4CA.

KOV 产品采用两种不同温度的锡温焊接工艺，快速察觉 MOV 本体的温升，利用锡-锡的热传递和熔融收缩，快速熔断电流流经的锡丝通道，形成较大的断开安全距离，增强了大电流断开时的熄弧能力，可适应更前端的过电压类别环境。The KOV product adopts a dual-temperature solder welding process, which can rapidly detect the temperature rise of the MOV body. By utilizing the thermal transfer between solders and the melting contraction effect, it quickly melts the solder channel through which current flows, forming a larger safe disconnection distance. This enhances the arc extinction capability during high-current interruption and enables adaptation to more severe overvoltage category environments.

KOV 系列产品在生产工艺、封装、包装和应用场景等方面完全和 MOV 重合，包括 ROHS、REACH 以及特殊场景。满足湿敏度 MSL 2 和波峰焊接。其工作温度等级达到了 105℃。KOV series products are identical to MOV components in terms of production process, packaging, and application scenarios, and fully comply with ROHS, REACH, and special scenario requirements. They meet the standards of Moisture Sensitivity Level 2 (MSL 2) and wave soldering, with an operating temperature grade (JEDEC JESD22-A119) of up to 105℃.



认证 Certification

Mark	Standards	File Number
	IEC61643-11	J 50602155
CQC	GB/T18802.331	checking
	UL1449	checking

应用 Applications

❖ 5G	❖ 漏电保护器	❖ 通讯电源	❖ 智能家居
❖ PSU	❖ 摄像头	❖ 防雷插排	❖ 医疗设备
❖ HVDC	❖ UPS	❖ 工业 PDU	❖ 万物互联
❖ LED 路灯	❖ 服务器	❖ 计量电表	❖ 信号接收机
❖ AI 机器人	❖ 打印机	❖ 智能照明	❖ 充电桩（站）
❖ 光伏	❖ 扫描仪	❖ 显示器	❖ 数据中心
❖ PD 适配器	❖ 复印机	❖ 工业计算机	❖ 特种电源
❖ 5G	❖ Leakage Protection Device	❖ Telecommunication Power Supply	❖ Smart Home
❖ PSU	❖ Camera	❖ Lightning Protection Power Strip	❖ Medical Equipment
❖ HVDC	❖ UPS	❖ Industrial PDU	❖ Internet of Everything
❖ LED Street Light	❖ Server	❖ Electricity Meter	❖ Signal Receiver
❖ AI Robot	❖ Printer	❖ Smart Lighting	❖ Charging Station
❖ Photovoltaic	❖ Scanner	❖ Monitor	❖ Data Center
❖ Power Delivery	❖ Copier	❖ Industrial Computer	❖ Special Power Supply

特征 Features

- ❖ 标准引脚外形
- ❖ 提供失效监测引脚
- ❖ 工作温度-40℃~ +105℃
- ❖ 储存温度范围-55℃ ~ +125℃
- ❖ 发热脱扣功能
- ❖ 支持波峰焊接
- ❖ 高达 5A 的限定电流下脱扣
- ❖ Standard pin configuration
- ❖ Equipped with failure detection pin
- ❖ Operating temperature: -40℃~ +105℃
- ❖ Storage temperature range: -55℃ ~ +125℃
- ❖ Thermal trip function
- ❖ Supports wave soldering
- ❖ Trips at a limited current of up to 5A

关键参数的使用范围 Rated value of key characteristics

特性 Characteristics	数值 Value	单位 Units
最大可持续工作电压 Maximum continuous operating voltage V_{MAC}	50~750	V
工作环境温度范围 Operating Ambient Temperature Range T_A	-40 ~ +105	°C
储存温度范围 Storage Temperature Range T_{STG}	-55 ~ +125	°C
单次冲击能量额定值 Single-Pulse Energy Capability - For 10/1000 Wave E_M	324/660	J
温度脱扣时的断开电流能力 Thermal Protection Isolation Current Capability (when operated)	5	A

产品型号代码 Part Number Code

KOV **14** **D** - **XXX** **I** **b** **@** **#**
 I II III IV V VI VII VIII

character meaning:

- I 温度保护系列。means Product Series (Thermally Protected).
- II 元件直径或边长。means Element Diameter, 14: ϕ 14mm, 20: ϕ 20mm.
- III 元件形式（圆片或方片）。means Element type, D: Disk, S: Square.
- IV 最大持续工作电压。means AC maximum continuous operating voltage.
- V 脱扣形式。TCO type . T: 易熔连接体 Fuse Link. it could also be other letters.
- VI 脚位数。means Pin type. b:2-Pin(Two-lead), Null: 3-Pin(Three-lead).
- VII 后缀，可以是字母 A-Z 或不加。Maybe a letters A to Z, or blank.
- VIII 后缀，可以是数字 0-9 或不加。Maybe a character number from 0 to 9, or blank.

性能参数 Performance Parameters

Type	Maximum Continuous Operating Voltage ^a		T2	T3	Varistors Voltage ^d	TPV	Disc Diameter	measured limiting voltage ^f (Max.)		Energy ^g 10/1000	Typical Capacitance @1 kHz	System operating voltage ^h
	V_{MAC} (V)	V_{MDC} (V)	I_n^b (kA)	U_{OC}^c (kV)	V_V (V)			I_{psc}^e (A)	V_C (V)			
KOV14D-050TA ⁱ	50	65	/	6	82	5	14	135	295	27	2400	50
KOV20D-050TA	50	65	5	10	82	5	20	135	295	56	4900	50
KOV14D-060TA	60	85	/	6	100	5	14	165	375	33	2000	60
KOV20D-060TA	60	85	5	10	100	5	20	165	375	70	4000	60
KOV14D-115TA	115	150	/	6	180	5	14	300	575	60	1100	115
KOV20D-115TA	115	150	5	10	180	5	20	300	575	130	2200	115
KOV14D-130TA	130	170	/	6	200	5	14	340	630	70	1000	130
KOV20D-130TA	130	170	5	10	200	5	20	340	630	140	2000	130
KOV14D-140TA	140	180	/	6	220	5	14	360	690	78	900	140
KOV20D-140TA	140	180	5	10	220	5	20	360	690	155	1800	140
KOV14D-150TA	150	200	/	6	240	5	14	395	730	84	830	150

Type	Maximum Continuous Operating Voltage ^a		T2 8/20	T3 1.2/50	Varistors Voltage ^d ±10%	TPV	Disc Diameter	measured limiting voltage ^f (Max.)		Energy ^g 10/1000	Typical Capacitance @1 kHz	System operating voltage ^h
	V _{MAC} (V)	V _{MDC} (V)	I _n ^b (kA)	U _{oc} ^c (kV)	V _V (V)	I _p ^e A	(mm)	V _c I _p :50/100A	U _p I _n	(J)	(pF)	V _r
KOV20D-150TA	150	200	5	10	240	5	20	395	730	168	1650	150
KOV14D-175TA	175	225	/	6	275	5	14	455	750	99	740	175
KOV20D-175TA	175	225	5	10	275	5	20	455	750	190	1500	175
KOV14D-190TA	190	250	/	6	300	5	14	500	850	108	670	190
KOV20D-190TA	190	250	5	10	300	5	20	500	850	210	1300	190
KOV14D-210TA	210	275	/	6	330	5	14	550	915	115	610	210
KOV20D-210TA	210	275	5	10	330	5	20	550	915	228	1200	210
KOV14D-230TA	230	300	/	6	360	5	14	595	1000	130	560	230
KOV20D-230TA	230	300	5	10	360	5	20	595	1000	255	1100	230
KOV14D-250TA	250	320	/	6	390	5	14	650	1100	140	500	250
KOV20D-250TA	250	320	5	10	390	5	20	650	1100	275	1000	250
KOV14D-275TA	275	350	/	6	430	5	14	710	1190	155	460	275
KOV20D-275TA	275	350	5	10	430	5	20	710	1190	305	930	275
KOV14D-300TA	300	385	/	6	470	5	14	775	1310	175	430	300
KOV20D-300TA	300	385	5	10	470	5	20	775	1310	350	850	300
KOV14D-320TA	320	415	/	6	510	5	14	845	1420	180	390	320
KOV20D-320TA	320	415	5	10	510	5	20	845	1420	360	780	320
KOV14D-350TA	350	460	/	6	560	5	14	930	1600	185	360	350
KOV20D-350TA	350	460	5	10	560	5	20	930	1600	380	970	350
KOV14D-385TA	385	505	/	6	620	5	14	1025	1710	190	320	385
KOV20D-385TA	385	505	5	10	620	5	20	1025	1710	390	650	385
KOV14D-420TA	420	560	/	6	680	5	14	1120	1850	200	290	420
KOV20D-420TA	420	560	5	10	680	5	20	1120	1850	400	600	420
KOV14D-460TA	460	615	/	6	750	5	14	1240	2040	210	270	460
KOV20D-460TA	460	615	5	10	750	5	20	1240	2040	420	530	460
KOV14D-510TA	510	670	/	6	820	5	14	1355	2230	235	240	510
KOV20D-510TA	510	670	5	10	820	5	20	1355	2230	460	500	510
KOV14D-550TA	550	745	/	6	910	5	14	1500	2480	255	220	550
KOV20D-550TA	550	745	5	10	910	5	20	1500	2480	510	440	550
KOV14D-620TA	620	820	/	6	1000	5	14	1650	2720	280	200	620
KOV20D-620TA	620	820	/	10	1000	5	20	1650	2720	565	400	620
KOV14D-680TA	680	890	/	6	1100	5	14	1815	3000	310	180	680
KOV20D-680TA	680	890	/	10	1100	5	20	1815	3000	620	360	680
KOV14D-750TA	750	990	/	6	1200	5	14	1980	3270	324	160	750
KOV20D-750TA	750	990	/	10	1200	5	20	1980	3270	660	350	750

NOTE:

a: 请参阅 IEC 61643-331:2020 中 3.1.1.8 和 3.1.1.1.9 的定义。

Refer to the definitions of 3.1.1.8 and 3.1.1.1.9 in IEC 61643-331:2020.

b: 根据 IEC 61643-331:2020 的要求, 测试电流应为 8/20 波形, 在脉冲间隙上施加 MCOV, 并且应至少能够承受 19 次 I_n 类电流冲击。

According to the requirements of IEC 61643-331:2020, the test current shall be an 8/20 waveform, with MCOV applied to the impulse gap, and it shall withstand at least 19 impacts of I_n -class current.

c: 请参阅 IEC 61643-11 中 “8.3.4.5 Class III operating duty tests” 的要求。

Refer to the definitions of ‘8.3.4.5 Class III operating duty tests’ in IEC 61643-11.

d: 在直流电流为 1mA 时测量金属氧化物压敏电阻 (MOV) 端子间的电压, 不得超过其额定值的 $\pm 10\%$ 。

The voltage measured across the terminals of a MOV (Metal Oxide Varistor) at DC current of 1mA shall not exceed $\pm 10\%$ of its rated value.

e: 依据 GB/T18802.331-2024 中 “6.2.4.11 MOV 的 TOV 耐受时间” 和 “6.2.4.12 TPV 在暂时过电压下的限定电流” 的测试要求。

According to the test requirements in GB/T18802.331-2024, ‘6.2.4.11 TOV withstand time of MOV’ and ‘6.2.4.12 Limited current of TPV under temporary overvoltage’.

f: 依据 GB/T18802.331-2024 中 “5.3.5 钳位电压 V_c ” 的测试要求, 表中 14D 采用 $I_p: 50A$, 20D 采用 $I_p: 100A$ 。

According to the test requirements for “5.3.5 Clamping Voltage V_c ” in GB/T 18802.331-2024, the table shows that 14D uses $I_p: 50A$, and 20D uses $I_p: 100A$.

g: 在 IEC61051-1 中, E_M 是 MOV 的额定冲击能量值, 它是压敏电阻在环境温度为 25°C 时, 能够承受一次 10/1000 电流脉冲或 2ms 矩形波脉冲的最大脉冲能量。此处使用 10/1000 额定值。

In IEC61051-1, E_M is the rated energy value of the MOV and it is the maximum pulse energy that the varistor is able to withstand one time when it is exposed to a 10/1000 current pulse or a 2ms rectangular wave pulse at an ambient of 25 °C.

h: 按照 GB4943 和 IEC62368-1 的要求, MOV 的选用必须满足系统对应工作电压的过载实验, 此栏为推荐值。

According to the requirements of GB4943 and IEC62368-1, the selection of MOVs must meet the overload test for the corresponding operating voltage of the system. This column shows the recommended values.

i: 括号中的文字是后缀, 可以根据命名规则进行修改。这些后缀不表示与电气性能相关的任何含义。

The text in parentheses is a suffix and can be modified according to the naming rules. These suffixes do not represent any meaning related to electrical performance.

应用提示 Application Tips

项目 Item	参考和建议 References and Suggestions
失效监测 Failure Monitoring	<p>可使用 3-Pin 的产品实现器件失效监测, 在使用正常时电涌的泄流通路是 1、2 脚之间, 2、3 脚是直接连接的, 当 MOV 失效后, 2、3 脚会呈现开路状态, 可由此设定指示灯或其他的遥信转换输出功能。通常 2、3 脚的额定电流可达到 5-10A, 但是不建议用 2、3 脚的开关状态来控制被保护负载的电源供电, 如果强行使用, 请充分评估 2、3 脚的断开对被保护负载的运行影响, 对此产生的损失或纠纷不承担责任。</p> <p>A 3-pin product can be used to achieve device failure monitoring. Under normal operation, the surge discharge path is between pins 1 and 2, while pin 2 and 3 are directly connected. When the MOV fails, pin 2 and 3 will exhibit an open-circuit state, allowing for the setup of indicator lights or other remote signaling conversion output functions based on this. Typically, the rated current of pin 2 and 3 can reach 5-10A. However, it is not recommended to use the switching state of pin 2 and 3 to control the power supply of the protected load. If forced to use it, please fully evaluate the impact of the disconnection of pin 2 and 3 on the operation of the protected load. No liability will be assumed for any losses or disputes arising therefrom.</p>

温度控制 Temperature Control	<p>由于元件内部集成了低温焊接材料并依靠此材料发挥断开作用，因此在存储、运输、安装、使用等环节都要考虑温度的影响。在元件焊接时要遵循焊接曲线要求并先用小批试制，确认后大批量使用。元件在 PCB 上的安装位置要远离发热器件或热风出口；也要远离对温度敏感的器件，因为本元件失效时会有短时升温。</p> <p>Since the component internally integrates a low-temperature soldering material and relies on this material to perform the disconnect function, the impact of temperature must be considered in all stages including storage, transportation, installation, and use. When soldering the component, follow the soldering curve requirements and first conduct small-batch trial production; after confirmation, proceed with mass production. The installation position of the component on the PCB should be kept away from heat-generating components or hot air outlets, and also away from temperature-sensitive components, because this component may experience a short-term temperature rise upon failure.</p>
温度降额 Temperature derating	<p>元件的最大持续运行电压 V_c、额定通流 I_n 和额定耗散能量 E_m 参数有温度升高而降额的趋势，切不可超越元件的工作温度 (T_i) 和储存温度 (T_{STG}) 使用。</p> <p>The parameters of the component's maximum continuous operating voltage (V_c), rated current handling capacity (I_n), and rated dissipated energy (E_m) tend to derate as temperature rises. Do not exceed the component's operating temperature (T_A) and storage temperature (T_{STG}) under any circumstances.</p>
额定通流和额定耗散能量 I_n 、 I_{max} 、 E_m	<p>由于 MOV 的额定耗散能量值有限，决定了 MOV 的 I_n、I_{max}、E_m 值不能被超额适用，可按照系统设备的强制性安规或特定的 EMC 及电涌防护的标准选用，在允许的情况下尽量选用 I_n、I_{max}、E_m 值更高的器件。</p> <p>Since the rated dissipated energy value of the MOV is limited, it dictates that the I_n, I_{max}, and E_m values of the MOV cannot be exceeded in application. These parameters can be selected in accordance with the mandatory safety regulations for system equipment or specific standards for EMC and surge protection. Whenever permissible, devices with higher I_n, I_{max}, and E_m values should be prioritized.</p> <p>在典型满足 IEC 61000-4-5 的设施中，需要提供开路电压 U_{OC} (组合波) 共模 (短路电阻 $12\ \Omega$) 40 次和差模 (短路电阻 $2\ \Omega$) 40 次的脉冲冲击，如果设施内部做了全模保护 (L-N、L/N-PE)，此时所采用 MOV 可能会承受高达 120 次的脉冲，因此选用 MOV 的额定通流和额定耗散能量 (I_n、I_{max}、E_m) 时，一定要考虑其中差异，至少要按照 MOV 的额定通流和额定耗散能量的 2 倍来选取。</p> <p>In a typical facility compliant with IEC 61000-4-5, it is required to apply pulse impacts with U_{OC} (combination wave) of 40 times in common mode (with a short-circuit resistance of $12\ \Omega$) and 40 times in differential mode (with a short-circuit resistance of $2\ \Omega$). If the facility is equipped with full-mode protection (L-N, L/N-PE) internally, the adopted MOV may be subjected to up to 120 pulses. So selecting the MOV for their rated current-carrying capacity and rated energy dissipation (I_n, I_{max}, E_m), it is essential to consider this difference. They should be selected with at least twice the rated current-carrying capacity and rated energy dissipation of the MOV.</p>
脱扣功能 thermally operated link/thermal cut off (TCO)	<p>脱扣功能利用了 MOV 本体在不同电流的功耗发热，由于 MOV 的额定耗散能量值有限，因此我们确认了在 $2 * V_{MAC}$ 下的脱扣电流 I_{PSC}，此值是能验证的最大值，当测试时实际电流比 I_{PSC} 低时，脱扣时间会变长但不会出现不能脱扣的风险。如果您要选用更大的 I_{PSC}，则需要选用 I_{PSC} 更高的产品或者直接选用专业板载 SPD。</p> <p>The trip function utilizes the heat generated by power dissipation in the MOV body at different currents. Since the rated dissipated energy value of the MOV is limited, we have determined the trip current I_{PSC} at twice V_{MAC}, which is the maximum verifiable value. When the actual current during testing is lower than I_{PSC}, the trip time will increase, but there is no risk of failure to trip. If you wish to select a larger I_{PSC}, you need to choose a product with a higher I_{PSC} or directly opt for a professional on-board SPD.</p>
钳位电压和限制电压 V_c and V_n	<p>尽管内部集成了温度脱扣装置，其产生的寄生电感、电容、电阻几乎不可测量，器件的钳位电压 V_c 和限制电压 V_n 和同电压等级的 MOV 一致，不需要额外考虑此二者的降低。</p> <p>Although the device internally integrates a temperature tripping device, the resulting parasitic inductance, capacitance, and resistance are almost immeasurable. The device's clamping voltage (V_c) and limiting voltage (V_n) are consistent with those of a Metal Oxide Varistor (MOV) of the same voltage rating, and no additional consideration is required for the reduction of these two voltages.</p>

引脚及尺寸 Lead Configurations and Dimensions

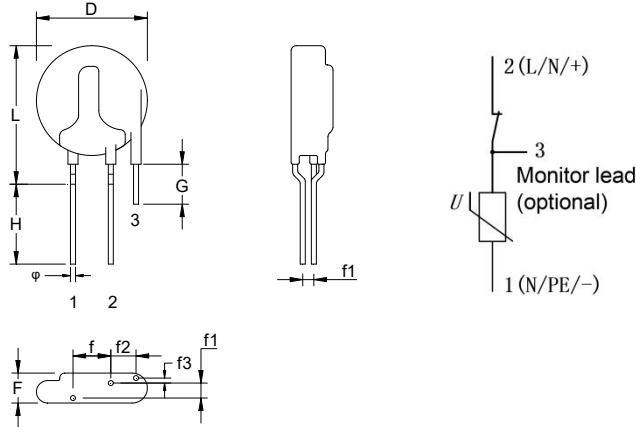

Table1

Dimension	Units (mm)		Units (in.)		Dimension	Units (mm)		Units (in.)	
	14D Size	20D Size	14D Size	20D Size		14D Size	20D Size	14D Size	20D Size
D(±2.0).	15	21	0.748	0.945	Φ(±0.05)	0.8	1.0	0.031	0.039
L(max).	22	28	0.866	1.024	f(±0.7)	7.5	7.5	0.295	0.295
H(min).	20	20	0.591	0.591	f2(±1.0)	5.0	5.0	0.197	0.197
G(min).	6.5	6.5	0.236	0.236	f3(±1.0)	1.0	1.0	0.039	0.039

TABLE 2

产品型号 Type Number	F ^a			
	Units (mm)		Units (in.)	
	14D Size	20D Size	14D Size	20D Size
KOVxx ^b D50Txxx ^c	6.0(±2.0)	7.0(±2.0)	0.236(±0.079)	0.276(±0.079)
KOVxxD60Txxx	6.0(±2.0)	7.0(±2.0)	0.236(±0.079)	0.276(±0.079)
KOVxxD115Txxx	6.0(±2.0)	7.0(±2.0)	0.236(±0.079)	0.276(±0.079)
KOVxxD130Txxx	6.2(±2.0)	7.2(±2.0)	0.244(±0.079)	0.283(±0.079)
KOVxxD140Txxx	6.2(±2.0)	7.2(±2.0)	0.244(±0.079)	0.283(±0.079)
KOVxxD150Txxx	6.3(±2.0)	7.3(±2.0)	0.248(±0.079)	0.287(±0.079)
KOVxxD175Txxx	6.5(±2.0)	7.5(±2.0)	0.256(±0.079)	0.295(±0.079)
KOVxxD190Txxx	6.5(±2.0)	7.5(±2.0)	0.256(±0.079)	0.295(±0.079)
KOVxxD210Txxx	6.7(±2.0)	7.7(±2.0)	0.264(±0.079)	0.303(±0.079)
KOVxxD230Txxx	6.8(±2.0)	7.8(±2.0)	0.268(±0.079)	0.307(±0.079)
KOVxxD275Txxx	7.2(±2.0)	8.2(±2.0)	0.283(±0.079)	0.323(±0.079)
KOVxxD300Txxx	7.4(±2.0)	8.4(±2.0)	0.291(±0.079)	0.331(±0.079)
KOVxxD320Txxx	7.6(±2.0)	8.6(±2.0)	0.299(±0.079)	0.339(±0.079)
KOVxxD350Txxx	7.8(±2.0)	8.8(±2.0)	0.307(±0.079)	0.346(±0.079)
KOVxxD385Txxx	8.1(±2.0)	9.1(±2.0)	0.319(±0.079)	0.358(±0.079)
KOVxxD420Txxx	8.4(±2.0)	9.4(±2.0)	0.331(±0.079)	0.37(±0.079)
KOVxxD460Txxx	8.8(±2.0)	9.8(±2.0)	0.346(±0.079)	0.386(±0.079)
KOVxxD510Txxx	9.1(±2.0)	10.1(±2.0)	0.358(±0.079)	0.398(±0.079)
KOVxxD550Txxx	8.8(±2.0)	9.8(±2.0)	0.346(±0.079)	0.386(±0.079)
KOVxxD620Txxx	9.2(±2.0)	10.2(±2.0)	0.362(±0.079)	0.402(±0.079)
KOVxxD680Txxx	9.6(±2.0)	10.6(±2.0)	0.378(±0.079)	0.417(±0.079)
KOVxxD750Txxx	10.0(±2.0)	11.0(±2.0)	0.394(±0.079)	0.433(±0.079)

TABLE 3

产品型号 Type Number	f1 ^a			
	Units (mm)		Units (in.)	
	14D Size	20D Size	14D Size	20D Size
KOVxx ^b D50Txxx ^c	1.0(±1.0)	1.0(±1.0)	0.039(±0.039)	0.039(±0.039)
KOVxxD60Txxx	1.0(±1.0)	1.0(±1.0)	0.039(±0.039)	0.039(±0.039)
KOVxxD115Txxx	1.0(±1.0)	1.0(±1.0)	0.039(±0.039)	0.039(±0.039)
KOVxxD130Txxx	1.0(±1.0)	1.0(±1.0)	0.039(±0.039)	0.039(±0.039)
KOVxxD140Txxx	1.0(±1.0)	1.0(±1.0)	0.039(±0.039)	0.039(±0.039)
KOVxxD150Txxx	1.0(±1.0)	1.0(±1.0)	0.039(±0.039)	0.039(±0.039)
KOVxxD175Txxx	1.0(±1.0)	1.0(±1.0)	0.039(±0.039)	0.039(±0.039)
KOVxxD190Txxx	1.0(±1.0)	1.0(±1.0)	0.039(±0.039)	0.039(±0.039)
KOVxxD210Txxx	1.0(±1.0)	1.0(±1.0)	0.039(±0.039)	0.039(±0.039)
KOVxxD230Txxx	1.0(±1.0)	1.0(±1.0)	0.039(±0.039)	0.039(±0.039)
KOVxxD275Txxx	1.0(±1.0)	1.0(±1.0)	0.039(±0.039)	0.039(±0.039)
KOVxxD300Txxx	1.0(±1.0)	1.0(±1.0)	0.039(±0.039)	0.039(±0.039)
KOVxxD320Txxx	1.0(±1.0)	1.0(±1.0)	0.039(±0.039)	0.039(±0.039)
KOVxxD350Txxx	1.0(±1.0)	1.0(±1.0)	0.039(±0.039)	0.039(±0.039)
KOVxxD385Txxx	1.0(±1.0)	1.0(±1.0)	0.039(±0.039)	0.039(±0.039)
KOVxxD420Txxx	1.0(±1.0)	1.0(±1.0)	0.039(±0.039)	0.039(±0.039)
KOVxxD460Txxx	1.0(±1.0)	1.0(±1.0)	0.039(±0.039)	0.039(±0.039)
KOVxxD510Txxx	1.0(±1.0)	1.0(±1.0)	0.039(±0.039)	0.039(±0.039)
KOVxxD550Txxx	1.0(±1.0)	1.0(±1.0)	0.039(±0.039)	0.039(±0.039)
KOVxxD620Txxx	1.0(±1.0)	1.0(±1.0)	0.039(±0.039)	0.039(±0.039)
KOVxxD680Txxx	1.0(±1.0)	1.0(±1.0)	0.039(±0.039)	0.039(±0.039)
KOVxxD750Txxx	1.0(±1.0)	1.0(±1.0)	0.039(±0.039)	0.039(±0.039)

- a : 由于 f1 的尺寸数据随着压敏电压变化而变化, 请先索取样品并承认样品后开始大批上板使用。
 Since the dimensional data of f1 varies with the varistor voltage, please first request samples, approve them, and then commence large-scale board assembly and use.
- b : 型号中的瓷片直径代号, 此处用 xx 代替, 不指定具体的型号。
 The ceramic disc diameter code in the model number is represented by 'xx' here, without specifying a specific model.
- c : 型号中的其他代号, 此处用 xxx 代替, 不指定具体的型号。
 The other code in the model number is represented by 'xxx' here, without specifying a specific model.

标识 Logo Type

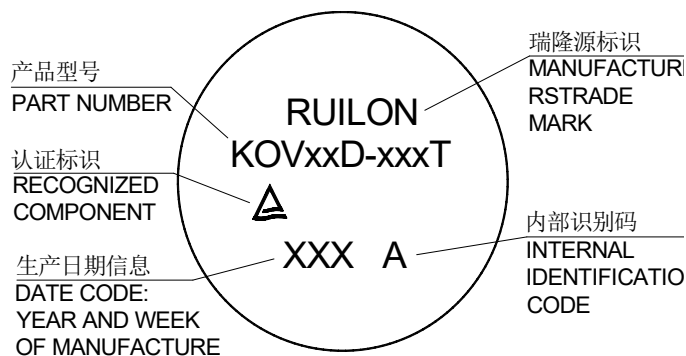

波峰焊参数 Wave Solder Profile

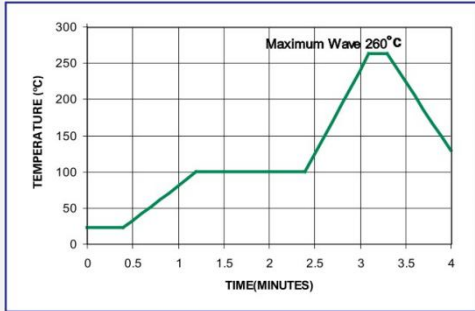

项目 Items	温度 Temp (°C)	时间 Time (s)
预热 Preheating	80 to 100	60 to 150
过锡 Dwelling	250 to 260	2 to 4

手工焊参数 Manual Solde

项目 Items	条件 Condition
烙铁头温度 Iron Temperature	350 °C (Max.)
焊接时间 Soldering Time	4 Seconds(Max.)
焊接点距产品底部的距离 Distance from the solde point to the bottom of the product	2mm(Min.)

包装信息 Packaging Information

散装 BULK:

Part Code	14 mm Disc		
	QTY/PE Bag (210*180*0.1mm)	QTY/Inner Box (260*208*55mm)	QTY/Carton (435*275*200mm)
KOV14D-050TA~KOV14D-550TA	200 pcs	2 bags per = 400 pcs	6 inner boxes = 2400 pcs
KOV14D-620TA~KOV14D-750TA	150 pcs	2 bags per = 300 pcs	6 inner boxes = 1800 pcs

Part Code	20 mm Disc		
	QTY/PE Bag (210*180*0.1mm)	QTY/Inner Box (260*208*55mm)	QTY/Carton (435*275*200mm)
KOV20D-050TA~KOV20D-550TA	150 pcs	2 bags per = 300 pcs	6 inner boxes = 1800 pcs
KOV20D-620TA~KOV20D-750TA	100 pcs	2 bags per = 200 pcs	6 inner boxes = 1200 pcs

声明 Disclaimer

本资料所提供的信息是准确可靠的。用户应独立评估所选产品用于其自身应用的适用性并进行测试。在产品选型应用前 RUILON 可以提供对应的参考测试。

The information provided in this document is accurate and reliable. Users should independently evaluate the suitability of the selected products for their own applications and conduct relevant tests. Before product selection and application, RUILON can provide corresponding reference tests.